

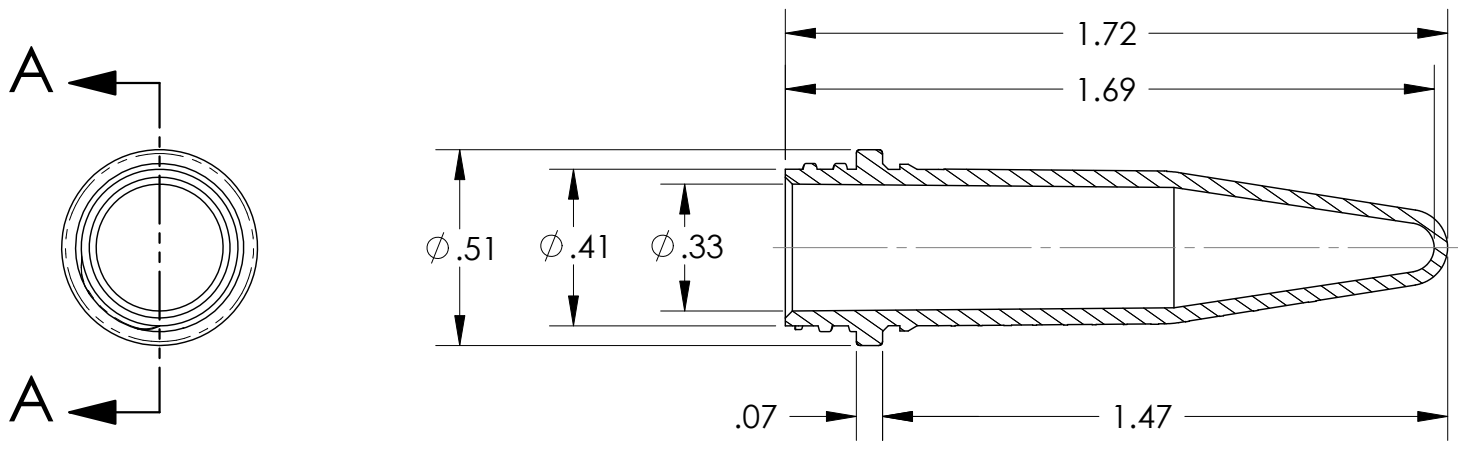

REVISIONS			
REV.	DESCRIPTION	DATE	APPROVED

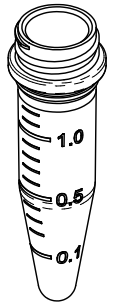

SECTION A-A



UNLESS OTHERWISE SPECIFIED DIMENSIONS ARE IN INCHES TOLERANCES ARE: FRACTIONS DECIMALS ANGLES +1/64 .XX ± .01 + 1 .XXX ± .001 .XXXX ± .0005	CAD GENERATED DRAWING, DO NOT MANUALLY UPDATE		 1310 Thurman Street Lodi CA, 95240 Ph: (209) 333-2120 Fx: (209) 333-8623 tooling@scientificspecialties.com
	APPROVALS DRAWN S. KRAMER CHECKED RESP ENG MFG ENG QUAL ENG	DATE 12/10/2004	
MATERIAL -- FINISH -- DO NOT SCALE DRAWING	SIZE SHRINK RATE A	REV. -- SCALE 2:1 JOB NO. SHEET 1 OF 1	

PRINTED 12/10/2004